

SLX Series

Straight-Side **Link Drive** Double Crank Power Presses

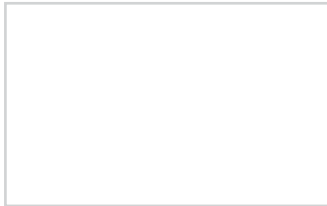

160 . 200 . 250 . 300 . 400 tons

SLX Series

Straight-Side **Link Drive** Double Crank Power Presses

The Stamtec SLX two-point straight side press with link motion drive technology is designed for stamping large parts or parts produced in long progressive dies that require deeper or more complex forming, at high single-stroking rates or in continuous mode, using either blanks or coil stock.

Stamtec's link motion drive technology is standard on the SLX series. With link motion, the slide velocity decreases by up to 40 percent during the working portion of the stroke so the material flows more effectively while the non-working portion of the stroke increases by an offsetting amount to maintain high production rates. The results are better quality parts produced at higher production rates. In addition, the slower speed of the working stroke reduces die impact, punch penetration, snap-through, noise and vibration, thereby increasing machine and die life.

Tonnage Range: 176 - 550

Delivery Time: 20 - 24 weeks



STANDARD Features

- High Performance Wet Type Clutch & Brake
- APC Controller
 - » Multiple Language Selection
 - » Crank Angle / S.P.M. Display
 - » Parameters Setup and Status Monitor
- Operation Mode Selection
 - Off / Inching / Safety One Stroke / Continuous
- Hydraulic Overload Protector (H.O.L.P.)
- Overrun Detector (Brake Monitor)
- Motorized Grease Pump
- Dual-coiled Solenoid Valve
- Floor Standing Electric Control Cabinet
- Motorized Slide Adjustment
- Digital Die Height Indicator (unit: 0.1mm)
- Total Counter, 6 digits
- Preset Counter, 6 digits
- Maintenance Counter, 6 digits
- Life Counter, 12 digits
- Electronic Rotary Cam Switch (6 spare channel)
- Air Ejector, 3/8", one channel
- Air Source Receptacle, 3/8", one channel
- Misfeed Detection Consent
- Power Receptacle (available only for single phase, 110V power source)
- Flywheel Safety Guard
- Portable 2-hand Pushbutton T-stand
- Inverter & Main Motor Reversing Circuit

SPECIFICATIONS

MODEL		SLX-160		SLX-200		SLX-250		SLX-300		SLX-400	
Type		D	B	D	B	D	B	D	B	D	B
Capacity	USTons	176		220		275		330		440	
	Metric Tons	160		200		250		300		400	
Rated tonnage point	in.	0.24	0.19	0.24	0.19	0.28	0.19	0.28	0.19	0.28	0.19
	mm	6	3	6	3	7	3	7	3	7	3
Speed	SPM	30	40	20	35	20	30	20	30	20	30
		55	85	50	70	40	60	35	50	35	50
Stroke length	in.	7.09	5.19	9.84	5.91	11.02	6.69	11.81	6.69	11.81	6.69
	mm	180	130	250	150	280	170	300	170	300	170
Die height (S. D. A. U.)	in.	17.72	15.75	19.69	15.75	21.65	15.75	21.65	15.75	21.65	15.75
	mm	450	400	500	450	550	450	550	450	550	450
Maximum upper die weight	lbs.	2645		3306		4850		5291		5291	
	kg	1200		1500		2200		2400		2400	
Slide adjustment	in.	3.94		4.72		4.72		4.72		4.72	
	mm	100		120		120		120		120	
Bolster area (L-R x B)	in.	70.87 x 29.92		86.61 x 37.01		98.43 x 39.37		98.43 x 39.37		98.43 x 39.37	
	mm	1800 x 760		2200 x 940		2500 x 1000		2500 x 1000		2500 x 1000	
Bolster thickness	in.	5.91		6.30		6.30		7.48		7.48	
	mm	150		160		160		190		190	
Slide area (L-R x F-B)	in.	62.99 x 25.59		72.84 x 29.53		82.68 x 35.43		86.61 x 35.43		86.61 x 35.43	
	mm	1600 x 650		1850 x 750		2100 x 900		2200 x 900		2200 x 900	
Side opening	in.	27.56 x 17.72		35.43 x 23.62		35.43 x 23.62		35.43 x 23.62		35.43 x 23.62	
	mm	700 x 450		900 x 600		900 x 600		900 x 600		900 x 600	
Main motor	HP x p	AC 20 x 4 + INV (V. S. 20 x 4)		AC 25 x 4 + INV (V. S. 25 x 4)		AC 30 x 4 + INV (V. S. 30 x 4)		AC 30 x 4 + INV (V. S. 30 x 4)		AC 40 x 4 + INV (V. S. 40 x 4)	
Slide adjusting motor	HP x p	1 x 4		2 x 4		2 x 4		2 x 4		2 x 4	

DIE CUSHION DEVICE											
Type		2P2C									
Capacity	USTons	6 x 2		11 x 2		15 x 2		15 x 2		15 x 2	
	Metric Tons	6.3 x 2		10 x 2		14 x 2		14 x 2		14 x 2	
Air pressure	PSI	102.41		96.01		128.01		128.01		128.01	
	Kg / cm ²	7.2		6.75		9		9		9	
Stroke length	in.	2.76		3.15		3.94		3.94		3.94	
	mm	70		80		100		100		100	
Pad area	in.	16.14 x 10.24 x 2pcs		21.26 x 13.78 x 2pcs		25.20 x 18.50 x 2pcs		25.20 x 18.50 x 2pcs		25.20 x 18.50 x 2pcs	
	mm	410 x 260 x 2pcs		540 x 350 x 2pcs		640 x 470 x 2pcs		640 x 470 x 2pcs		640 x 470 x 2pcs	

Slide Motion Characteristics

Slide velocity decreases while the non-working portion of the stroke increases

With a link motion drive, the slide velocity decreases by up to 40% during the working portion of the stroke. Material flow in the non-working portion of the stroke increases by an offsetting amount to maintain high production rates. The results are better quality parts produced at higher production speeds. In addition, the slower speed of the working stroke reduces die impact, punch penetration, snap-through, noise and vibration, increasing machine and die life.



Slide Motion Curve (B-Type)

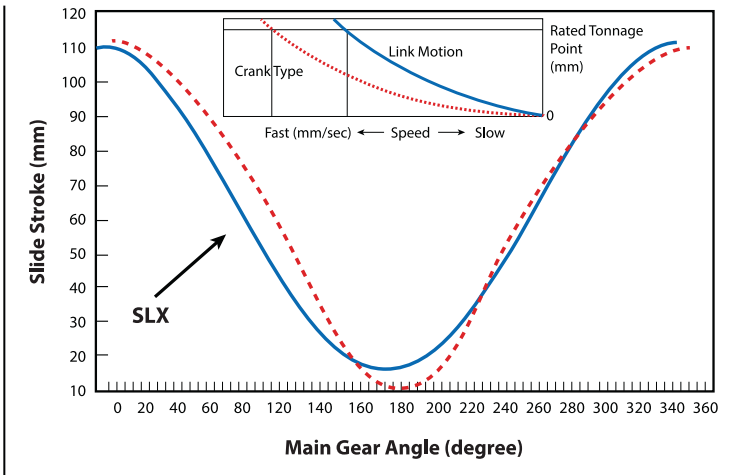

Stroke Capacity Diagram

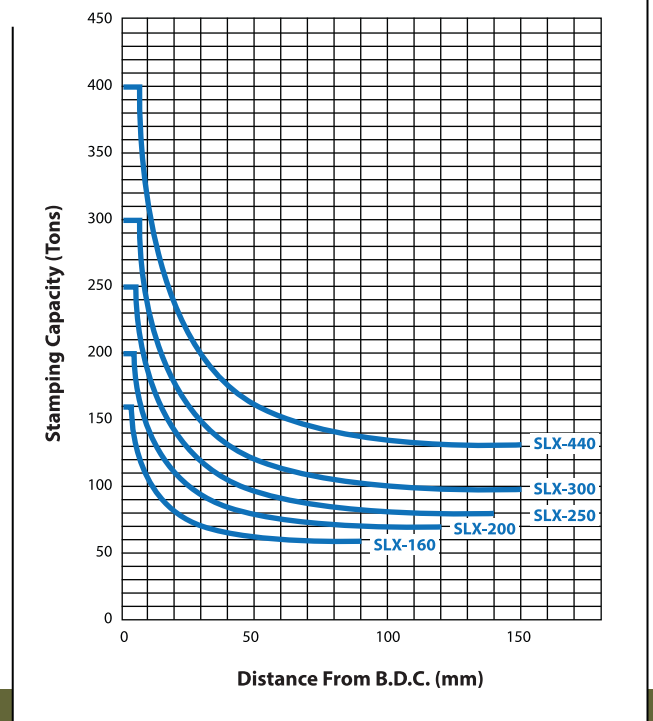

Slide Motion Curve (D-Type)

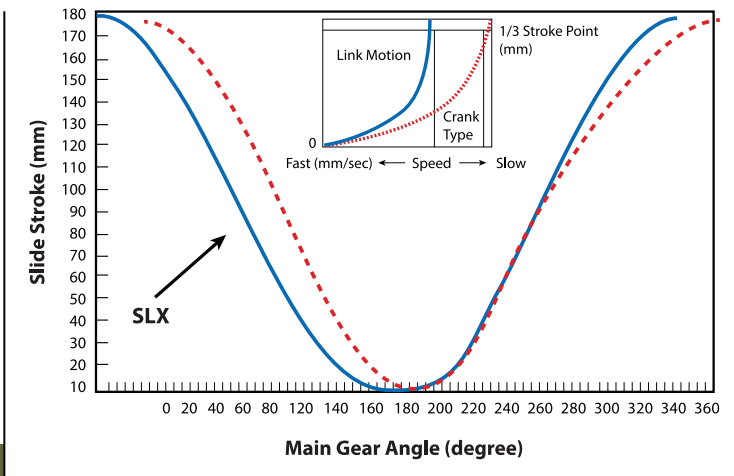

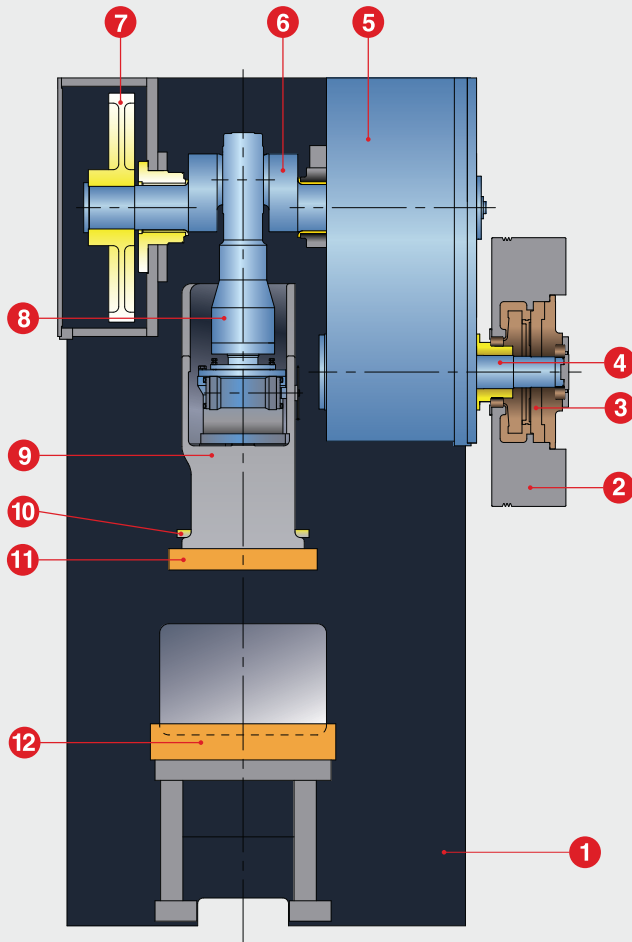

- | | |
|-----------------------|----------------------------|
| 1. Frame | 7. Gear |
| 2. Flywheel | 8. Link & Adjustable Screw |
| 3. Wet Clutch & Brake | 9. Slide |
| 4. Transmission Shaft | 10. Slide Knockout |
| 5. Gear Box | 11. Slide Plate |
| 6. Crankshaft | 12. Bolster |

6-Point Gibbing

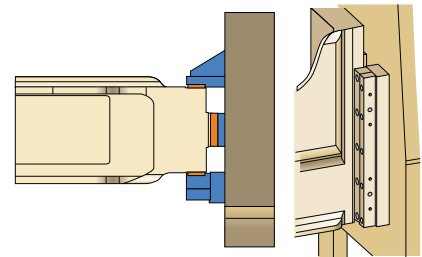

Extra-long gibbs fully guide the slide during the working portion of the stroke. Force to the slide is delivered vertically, eliminating lateral thrust against the gibbs, even under off-center loads.

Super Rigid Steel Frame

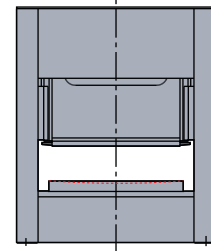

Stamtec SLX Series presses are designed to resist deflection, and provide accurate pressings and longer die life, even at full tonnage loads. The heavy, one-piece welded steel frame is fully stress relieved to provide a stable base.

Protect Press and Die with Fast Response HOLP

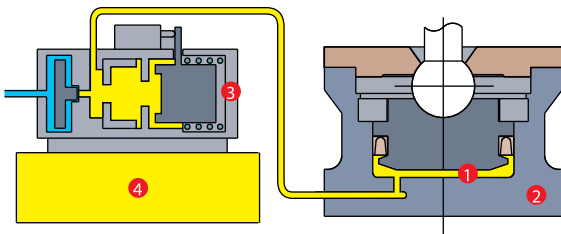

Stamtec's fast response Hydraulic Overload Protection (HOLP) system relieves the pressure of a tonnage overload in milliseconds and simultaneously issues an emergency stop signal to the press control, protecting the press and tooling from catastrophic damage. The HOLP system automatically re-pressurizes when the slide is inched back to top of stroke. The HOLP system can also be relieved manually to assist in un-sticking a die which is stuck on bottom of stroke.

Maintain Parallelism During Off Center Loads

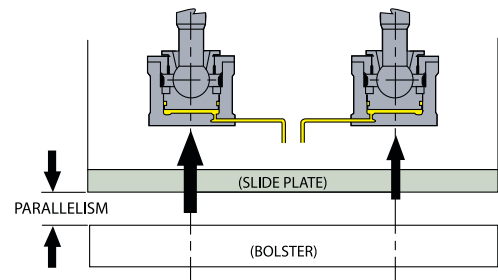

If unequal loads are applied across the slide, full oil pressure from the overload system is applied where required to retain the parallelism between slide plate and bolster for consistent quality of stampings and extended tooling life.

OPTIONAL Features

- Die Cushion
- Eddy current V. S. Motor
- Slide Knockout Device
- Safety Light Curtains
- Motorized Grease Pump
- Main Motor Reversing Circuit
- Portable 2-hand Pushbutton T- Stand
- Foot Switch
- Safety Block with plug
- Dual Solenoid Valve with Detector
- Inverter
- Misfeed Detector
- Flywheel Brake
- Anti-vibration Rubber Pads
- Anti-vibration Press Mounts
- Remote Monitoring and Control Systems
- Power Take-off Shaft
 - » Crankshaft Front-end Extension
- Quick Die Change System
 - » Upper
 - » Lower Die Clamps
 - » Die Lifters
 - » Die Arms
- Anchor Bolts & Foundation Plates
- Die Room Light
- NC Straightener Feed c/w
- Uncoiler (3 in 1)
- NC Roller Feeder
- Straightener c/w Uncoiler (2 in 1)

QUICK DIE CHANGE SYSTEMS

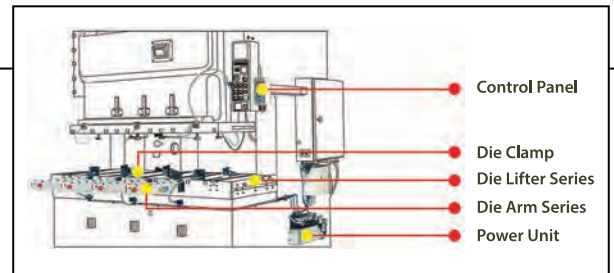
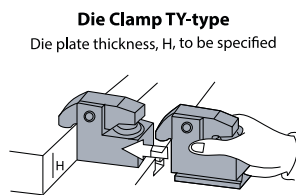
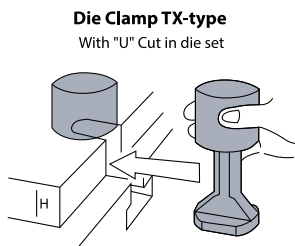

Option		Qty	Model	SLX-160	SLX-200	SLX-250	SLX-300	SLX-400
Die Clamp	Upper	TX-4 or TY-4	Clamping Force 4 tons / pc	8	8	8		
		TX-6 or TY-6	Clamping Force 6 tons / pc				8	8
	Lower	TX-2 or TY-2	Clamping Force 2 tons / pc	8	8			
		TX-4 or TY-4	Clamping Force 4 tons / pc			8		
		TX-6 or TY-6	Clamping Force 6 tons / pc				8	8
Die Lifter	DL28-700	Pay Load 1.0 tons / pc	4					
	DL28-900	Pay Load 1.3 tons / pc		4				
	DL28-1000	Pay Load 1.5 tons / pc			4	4	4	
Die Arm	RC-800-800	Pay Load 800 kg / pc	4					
	RC-1000-1000	Pay Load 1600 kg / pc		4	4	4	4	
Hydraulic Power Unit - FP6308U				FP6308U			FP6308U	

OUTLINE DIMENSIONS

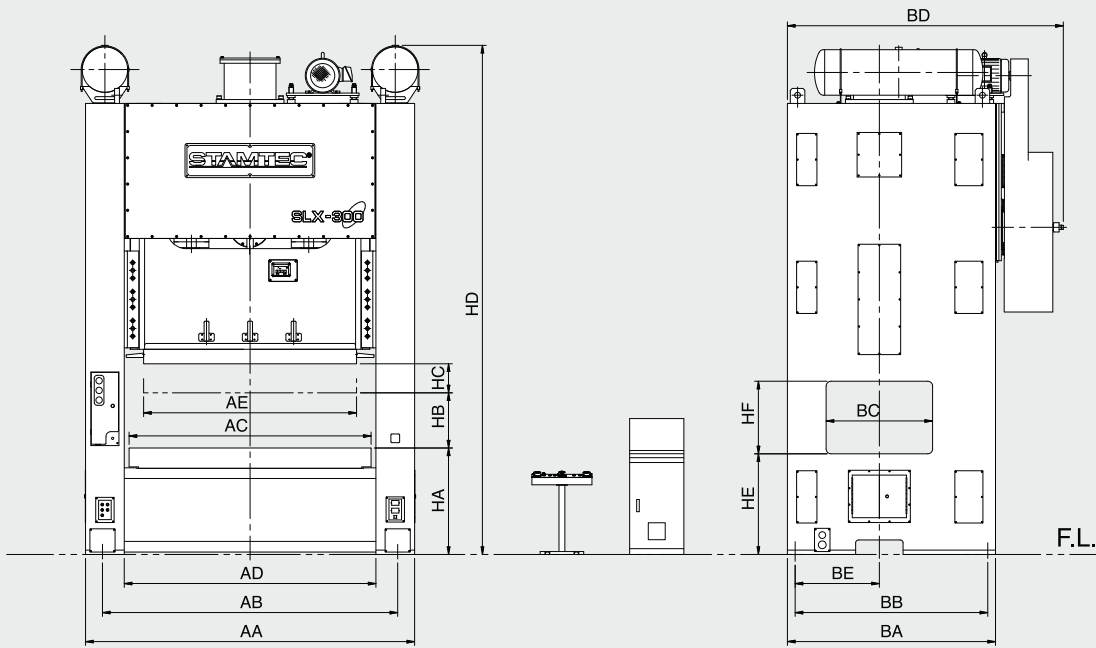

MODEL	SLX-160		SLX-200		SLX-250		SLX-300		SLX-400	
Type	D	B	D	B	D	B	D	B	D	B
AA	2630 mm (103.54 in)		3000 mm (118.11 in)		3310 mm (130.32 in)		3450 mm (135.83 in)		3450 mm (135.83 in)	
AB	2280 mm (89.76 in)		2650 mm (104.33 in)		2960 mm (116.54 in)		3100 mm (122.05 in)		3100 mm (122.05 in)	
AC	1800 mm (70.87 in)		2200 mm (86.61 in)		2500 mm (98.43 in)		2500 mm (98.43 in)		2500 mm (98.43 in)	
AD	1920 mm (75.59 in)		2290 mm (90.16 in)		2600 mm (102.36 in)		2650 mm (104.33 in)		2650 mm (104.33 in)	
AE	1600 mm (62.99 in)		1850 mm (72.84 in)		2100 mm (82.68 in)		2200 mm (86.61 in)		2200 mm (86.61 in)	
BA	1450 mm (57.09 in)		1600 mm (62.99 in)		1770 mm (69.69 in)		1870 mm (73.62 in)		2000 mm (78.74 in)	
BB	1290 mm (50.79 in)		1440 mm (56.70 in)		1610 mm (63.39 in)		1710 mm (67.32 in)		1840 mm (72.44 in)	
BC	700 mm (27.56 in)		900 mm (35.43 in)		900 mm (35.43 in)		900 mm (35.43 in)		900 mm (35.43 in)	
BD	2240 mm (88.19 in)		2390 mm (94.09 in)		2510 mm (98.82 in)		2600 mm (102.36 in)		2810 mm (110.63 in)	
BE	490 mm (19.29 in)		620 mm (24.41 in)		670 mm (26.38 in)		770 mm (30.32 in)		770 mm (30.32 in)	
HA	1000 mm (39.37 in)		1000 mm (39.37 in)		1100 mm (43.31 in)		1100 mm (43.31 in)		1200 mm (47.24 in)	
HB	450 mm (17.72 in)	400 mm (15.75 in)	500 mm (19.69 in)	450 mm (17.72 in)	550 mm (21.65 in)	450 mm (17.72 in)	550 mm (21.65 in)	450 mm (17.72 in)	550 mm (21.65 in)	450 mm (17.72 in)
HC	180 mm (7.09 in)	130 mm (5.19 in)	250 mm (9.84 in)	150 mm (5.91 in)	280 mm (11.02 in)	170 mm (6.70 in)	300 mm (11.81 in)	170 mm (6.70 in)	300 mm (11.81 in)	170 mm (6.70 in)
HD	4440 mm (174.80 in)	4365 mm (171.85)	4910 mm (193.31 in)	4810 mm (189.37 in)	5385 mm (212.01 in)	5230 mm (205.91 in)	5395 mm (212.40 in)	5230 mm (205.91 in)	5520 mm (217.32 in)	5355 mm (210.83 in)
HE	940 mm (37.01 in)		940 mm (37.01 in)		1040 mm (40.95 in)		1040 mm (40.95 in)		1140 mm (44.88 in)	
HF	450 mm (17.72 in)		600 mm (23.62 in)		600 mm (23.62 in)		600 mm (23.62 in)		600 mm (23.62 in)	

BOLSTER

Fig. 1

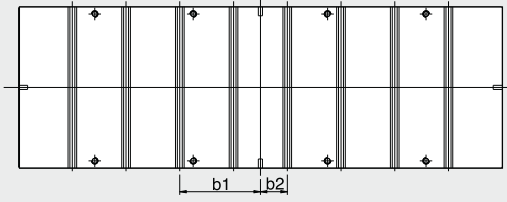

Fig. 2

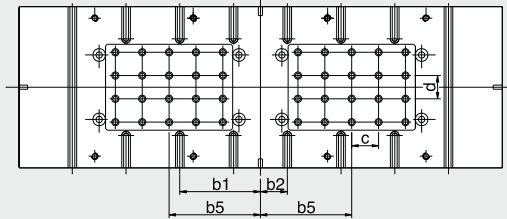

Fig. 3

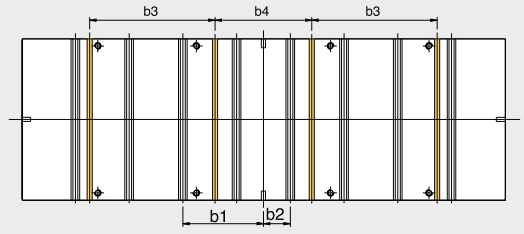
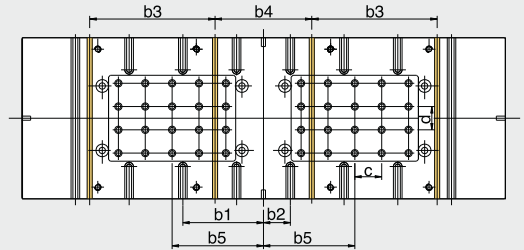
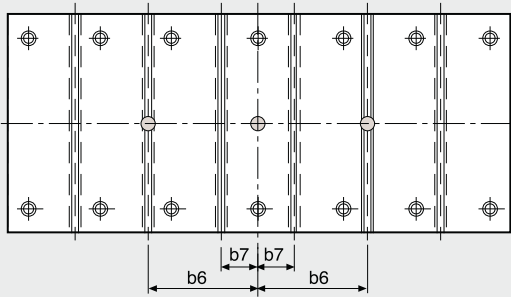

Fig. 4



MODEL		SLX-160	SLX-220	SLX-250	SLX-300	SLX-400
Bolster Area (LR x FB)		1800 x 760 mm (70.87 x 29.92 in)	2200 x 940 mm (86.62 x 37.01 in)	2500 x 1000 mm (98.43 x 39.37 in)	2500 x 1000 mm (98.43 x 39.37 in)	2500 x 1000 mm (98.43 x 39.37 in)
Type of T-Slot		A	B	B	B	B
No. of T-Slot		8	8	8	8	8
b1		375 mm (14.76 in)	375 mm (14.76 in)	450 mm (17.72 in)	450 mm (17.72 in)	450 mm (17.72 in)
b2		125 mm (4.92 in)	125 mm (4.92 in)	150 mm (5.91 in)	150 mm (5.91 in)	150 mm (5.91 in)
b3		450 mm (17.72 in)	710 mm (27.95 in)	680 mm (26.77 in)	680 mm (26.77 in)	680 mm (26.77 in)
b4		520 mm (20.47 in)	520 mm (20.47 in)	540 mm (21.26 in)	540 mm (21.26 in)	540 mm (21.26 in)
b5		415 mm (16.34 in)	455 mm (17.91 in)	510 mm (20.08 in)	510 mm (20.08 in)	510 mm (20.08 in)
Fig 2. Fig 4	No. of Pin Hole x Dia.	40 x Ø20 ^{+0.5} / _{+0.1}	48 x Ø28 ^{+0.5} / _{+0.1}	70 x Ø28 ^{+0.5} / _{+0.1}	70 x Ø28 ^{+0.5} / _{+0.1}	70 x Ø28 ^{+0.5} / _{+0.1}
	c x d	75 x 75 mm (2.95 x 2.95 in)	100 x 100 mm (3.94 x 3.94 in)	100 x 100 mm (3.94 x 3.94 in)	100 x 100 mm (3.94 x 3.94 in)	100 x 100 mm (3.94 x 3.94 in)

SLIDE PLATE



T-SLOT DETAIL

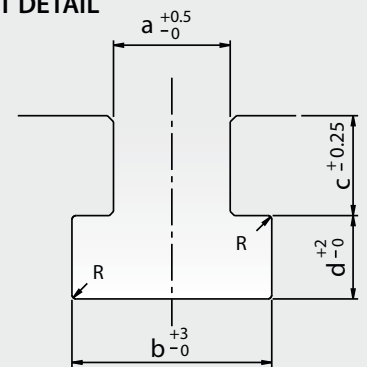

MODEL	SLX-160	SLX-200	SLX-250	SLX-300	SLX-400
Slide Plate Area (LR x FB)	1600 x 650 mm (62.99 x 25.59 in)	1850 x 750 mm (72.84 x 29.53 in)	2100 x 900 mm (82.68 x 35.43 in)	2200 x 900 (86.61 x 35.43 in)	2200 x 900 (86.61 x 35.43 in)
Type of T-Slot	A	B	B	B	B
No. of T-Slot	6	6	6	6	6
b6	375 mm (14.76 in)	375 mm (14.76 in)	450 mm (17.72 in)	450 mm (17.72 in)	450 mm (17.72 in)
b47	125 mm (4.92)	125 mm (4.92)	150 mm (5.91 in)	150 mm (5.91 in)	150 mm (5.91 in)

Dim.	Type	A	B
a		22 mm (0.87 in)	28 mm (1.10 in)
b		37 mm (1.46 in)	48 mm (1.89 in)
c		24 mm (0.95 in)	28 mm (1.10 in)
d		16 mm (0.63 in)	20 mm (0.79)
R		1 mm (0.04 in)	1 mm (0.04 in)

Press Controls

OmniLink 5100-APC (standard equipment)

- Model 806, 10.4" color touch screen with English or Spanish display, provides easy setting for control configuration, PLS, die protection, counters, etc.
- 1000 job storage and recall to provide quick, consistent set-ups.
- Eight (8) die protection / process monitoring inputs (up to 80 available optionally) located in the operator terminal. Nine monitoring modes are available for each die protection input.
- Eight (8) programmable limit switch outputs (up to 96 available optionally) are available to sequence and time automation with the press.
- 56 control inputs and 8 sets of dual-tracking safety control inputs (configurable) for performance and diagnostics with 56 additional inputs.
- Outputs for clutch and brake, as well as optional output relays configurable for specific functions related to lube systems, motor controls, hydraulic overloads, flywheel brakes, automation, etc.
- Screens to display the state of every input and output, lube system diagnostics, OIT diagnostics, configuration memory, and an event log with date, time and reason for the last 256 steps.
- Stopping time performance (brake) monitor, motion detection, clutch engagement time monitor.
- Stroking modes - Off, Inch, Automatic Timed Inch, Setup / Stop Time Test, Single Stroke (Cycle), and Continuous. (Optional modes - Automatic Single Stroke (Cycle), Maintained Continuous, and Continuous on Demand).
- Automatic Top Stop Compensation for use with variable speed presses.
- Four (4) nine-digit counters for stroke, parts, batch, and quality.
- Superior safety with powerful diversely redundant cross-checked dual micro-processor logic systems.
- Lasting value with rugged modular design and Link technical support.

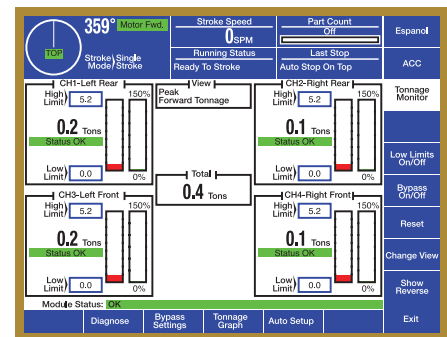
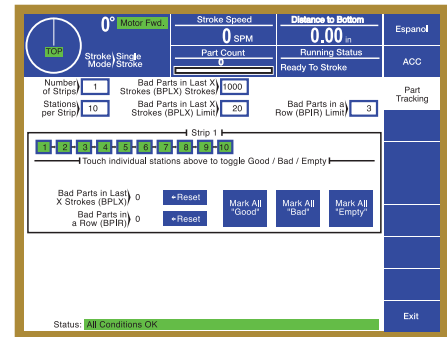
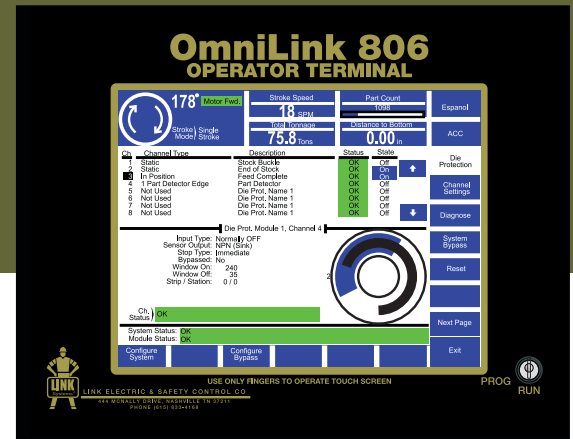

OPTIONAL Press Controls from manufacturers including:





STAMTEC®

METAL STAMPING & FORMING EQUIPMENT

Stamtec has been providing dependable, affordably priced metal stamping presses for almost 30 years in the North American market, and 60 years worldwide through our parent company Chin Fong. Our 72,000 sq. ft. sales, service, logistics, and assembly facility in Tennessee is home not only to North America's largest inventory of new presses and spare parts, but also our most important asset - our people. Our staff of engineering, sales, service, and support personnel are here to serve you in the most timely and professional manner. So, tap into our global strength, and grow with us as we grow with you!



GAP FRAME PRESSES

1-POINT AND 2-POINT



STRAIGHT SIDE PRESSES

1-POINT, 2-POINT AND 4-POINT



SERVO PRESSES

1-POINT AND 2-POINT
GAP AND STRAIGHT SIDE



FORGING PRESSES

WARM / HOT AND COLD



COIL FEEDING & HANDLING SYSTEMS

STAMTEC®

METAL STAMPING & FORMING EQUIPMENT

U.S.A. - STAMTEC, INC.

4160 Hillsboro Highway
Manchester, TN 37355 U.S.A.

TEL: +1-931-393-5050

FAX: +1-931-393-5060

sales@stamtec.com

www.stamtec.com

