

Single Point / Gap Frame Power Presses

OCP

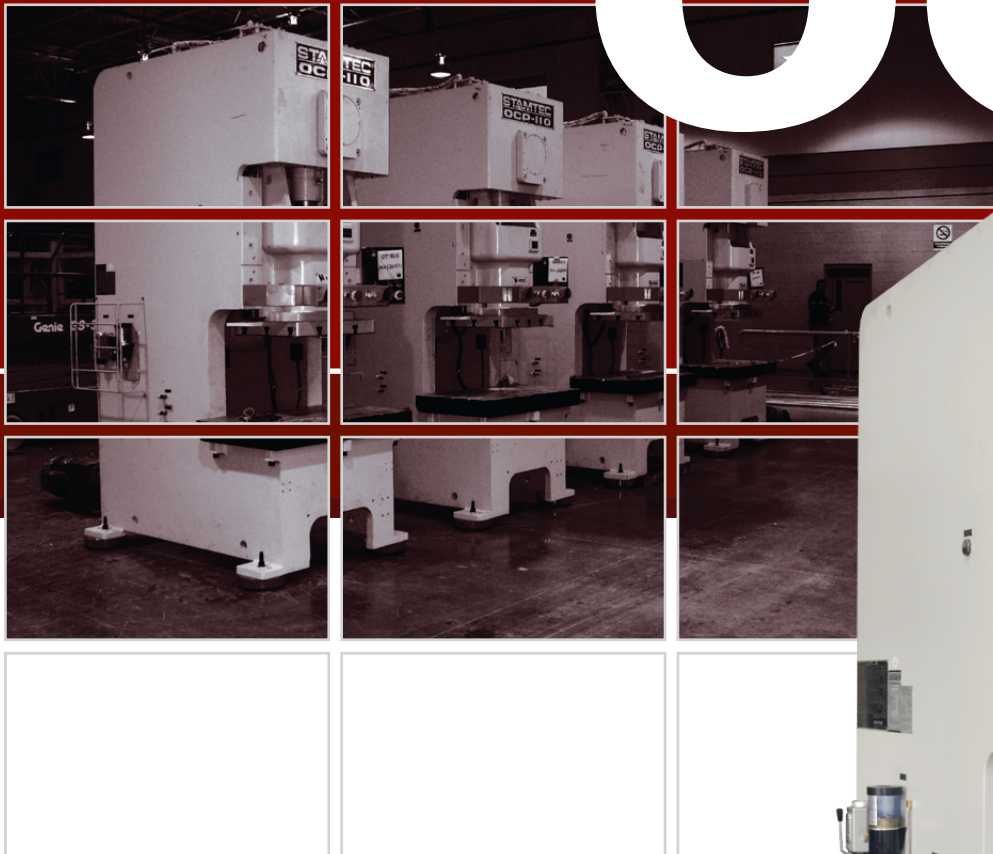

35 . 45 . 60 . 80 . 110 . 160 . 200 . 260 . 300 tons

Stamtec - OCP Series

World leader in GAP FRAME PRESS design

The new Stamtec OCP single point, gap frame press offers more features and more design advances than any similar machine. What's more, you'll be pleased at the very competitive pricing and the choice of many models from our large inventory of stock machines.

Features to improve your stamping performance and parts quality:

- High-performance wet clutch and brake
- Hydraulic overload protection
- Low-deflection, super rigid steel frame
- Extra long 6-point centered gibs
- Tight clearances/tolerances throughout
- Removable bolster and slide plate
- Automatic lubrication system
- Motorized slide adjustment
- Easy set-up and operation with advanced, user-friendly press controls

Visit: www.stamtec.com/ocp-series-gap-frame-press



STANDARD Features

- Wet clutch and brake
- Flywheel braking
- Hydraulic overload system
- Air counterbalance system
- Automatic lubrication system
- Motorized slide adjustment (on presses over 60 tons and up)
- Mechanical digital die height indicator on front of slide
- Removable, flanged, T-slotted slide plate and bolster
- Press control with:
 - » Programmable limit switches
 - » Programmable die monitor inputs
 - » Six-digit part and batch counters
 - » Interlocked die safety block

OPTIONAL Features

- Link motion drive technology
- Press controls from industry leaders (Link, Wintriss, Rockwell Automation (Allen-Bradley), Siemens, Mitsubishi, Delta)
- Anti-vibration press leveling mounts
- Safety light curtains
- Tonnage monitor
- Quick die change system
- Die cushion
- Compact servo feed line
- Knockout bar

Imperial Specifications

Model		OCP - 35			OCP - 45			OCP - 60			OCP - 80		
Type		S	H	V	S	H	V	S	H	V	S	H	V
Capacity	Tons	38.5			49.5			66			88		
Rated tonnage pt.	in.	0.13	0.09	0.13	0.13	0.09	0.13	0.16	0.09	0.16	0.2	0.13	0.2
Stroke	in.	2.36	1.57	3.54	2.76	1.97	4.33	3.15	1.97	5.11	3.84	2.36	5.91
Variable Speed (SPM)		70-135	90-180	50-95	65-130	85-175	50-95	60-120	80-165	40-85	50-100	65-140	40-75
Die height	in.	9.84	10.24	9.25	11.42	11.81	10.63	12.8	13.39	11.81	13.98	14.76	12.99
Max. upper die wt.	lbs.	661.39			661.39			661.39			760.60		
Slide adjustment	in.	1.97			2.36			2.76			3.15		
Bolster area	in.	30.71 * 13.39			33.47 * 17.32			35.43 * 20.47			39.37 * 23.62		
Bolster thickness	in.	2.76			3.54			3.54			3.94		
Slide area	in.	14.96 * 12.60			16.93 * 13.78			19.69 * 15.75			22.05 * 18.11		
Main motor	HP*P	5 * 4			5 * 4			7.5 * 4			10 * 4		
Working height	in.	31.50			31.50			31.50			32.68		
Slide adj. motor	kW*P	Manual			Manual			0.4 * 4			0.4 * 4		

Model		OCP - 110			OCP - 160			OCP - 200			OCP - 260			OCP - 300E		
Type		S	H	V	S	H	V	S	H	V	S	H	V	S	H	V
Capacity	Tons	121.25			176.37			220.46			286.60			330.69		
Rated tonnage pt.	in.	0.20	0.13	0.20	0.24	0.16	0.24	0.24	0.16	0.24	0.24	0.16	0.24	0.24	0.16	0.24
Stroke	in.	4.33	2.76	7.09	5.12	3.15	7.87	5.91	3.94	7.87	7.09	3.94	9.84	7.09	3.94	9.84
Speed (SPM)	Variable	45-90	60-130	30-65	35-70	50-100	20-50	35-70	45-95	20-50	30-60	35-75	20-40	30-50	35-75	20-40
Die height	in.	15.16	15.95	13.78	17.13	18.11	15.75	18.70	19.69	17.72	19.10	20.67	17.72	19.10	20.67	17.72
Max. upper die wt.	lbs.	992.08			1190.50			1763.70			1763.70			1763.70		
Slide adjustment	in.	3.54			3.94			4.33			4.72			4.72		
Bolster area	in.	45.28 * 26.77			49.21 * 29.92			55.12 * 32.28			59.06 * 33.07			36.22 * 27.56		
Bolster thickness	in.	4.72			5.91			6.30			7.09			7.09		
Slide area	in.	25.59 * 20.47			27.56 * 22.84			33.47 * 25.59			36.22 * 27.56			61.02 * 33.07		
Main motor	HP*P	15 * 4			20 * 4			20 * 4			25 * 4			30 * 4		
Working height	in.	33.27			36.02			40.16			44.10			44.10		
Slide adj. motor	kW*P	0.4 * 4			0.75 * 4			0.75 * 4			1.5 * 4			1.5 * 4		

Metric Specifications

Model		OCP - 35			OCP - 45			OCP - 60			OCP - 80		
Type		S	H	V	S	H	V	S	H	V	S	H	V
Capacity	Tons	35			45			60			80		
Rated tonnage pt.	mm	3.2	2.3	3.2	3.2	2.3	3.2	4	2.3	4	5	3.2	5
Stroke	mm	60	40	90	70	50	110	80	50	130	100	60	150
Variable Speed (SPM)		70-135	90-180	50-95	65-130	85-175	50-95	60-120	80-165	40-85	50-100	65-140	40-75
Die height	mm	250	260	235	290	300	270	325	340	300	355	375	330
Max. upper die wt.	kg	300			300			300			345		
Slide adjustment	mm	50			60			70			80		
Bolster area	mm	780 * 340			850 * 440			900 * 520			1000 * 600		
Bolster thickness	mm	70			90			90			100		
Slide area	mm	380 * 320			430 * 350			500 * 400			560 * 460		
Main motor	HP*P	5 * 4			5 * 4			7.5 * 4			10 * 4		
Working height	mm	800			800			800			830		
Slide adj. motor	kW*P	Manual			Manual			0.4 * 4			0.4 * 4		

Model		OCP - 110			OCP - 160			OCP - 200			OCP - 260			OCP - 300E		
Type		S	H	V	S	H	V	S	H	V	S	H	V	S	H	V
Capacity	Tons	110			160			200			260			300		
Rated tonnage pt.	mm	5	3.2	5	6	4	6	6	4	6	6	4	6	6	4	6
Stroke	mm	110	70	180	130	80	200	150	100	200	180	100	250	180	100	250
Speed (SPM)	Variable	45-90	60-130	30-65	35-70	50-100	20-50	35-70	45-95	20-50	30-60	35-75	20-40	30-50	35-75	20-40
Die height	mm	385	405	350	435	460	400	475	500	450	485	525	450	485	525	450
Max. upper die wt.	kg	450			540			800			800			800		
Slide adjustment	mm	90			100			110			120			120		
Bolster area	mm	1150 * 680			1250 * 760			1400 * 820			1550 * 840			920 * 700		
Bolster thickness	mm	120			150			160			120			180		
Slide area	mm	650 * 520			700 * 580			850 * 650			920 * 700			1550 * 840		
Main motor	HP*P	15 * 4			20 * 4			20 * 4			25 * 4			30 * 4		
Working height	mm	845			915			1020			1120			1120		
Slide adj. motor	kW*P	0.4 * 4			0.75 * 4			0.75 * 4			1.5 * 4			1.5 * 4		

Performance, Control, Torque & Reliability

Reliable and efficient performance from wet clutch and brake design

The Stamtec wet clutch delivers rated torque at relatively low air pressure, reducing lining wear and air consumption. Lining life is extended by the effective heat dissipation resulting from the linings running in an enclosed oil bath.

Low inertia significantly reduces lining wear. High performance is combined with low vibration and noise. Higher single stroke rates are achieved.

The OCP Series is such a compact design, it allows a larger capacity press to be accommodated in the same space as a smaller press. The space required for (4) traditional presses is space enough for (5) OCP Series presses.

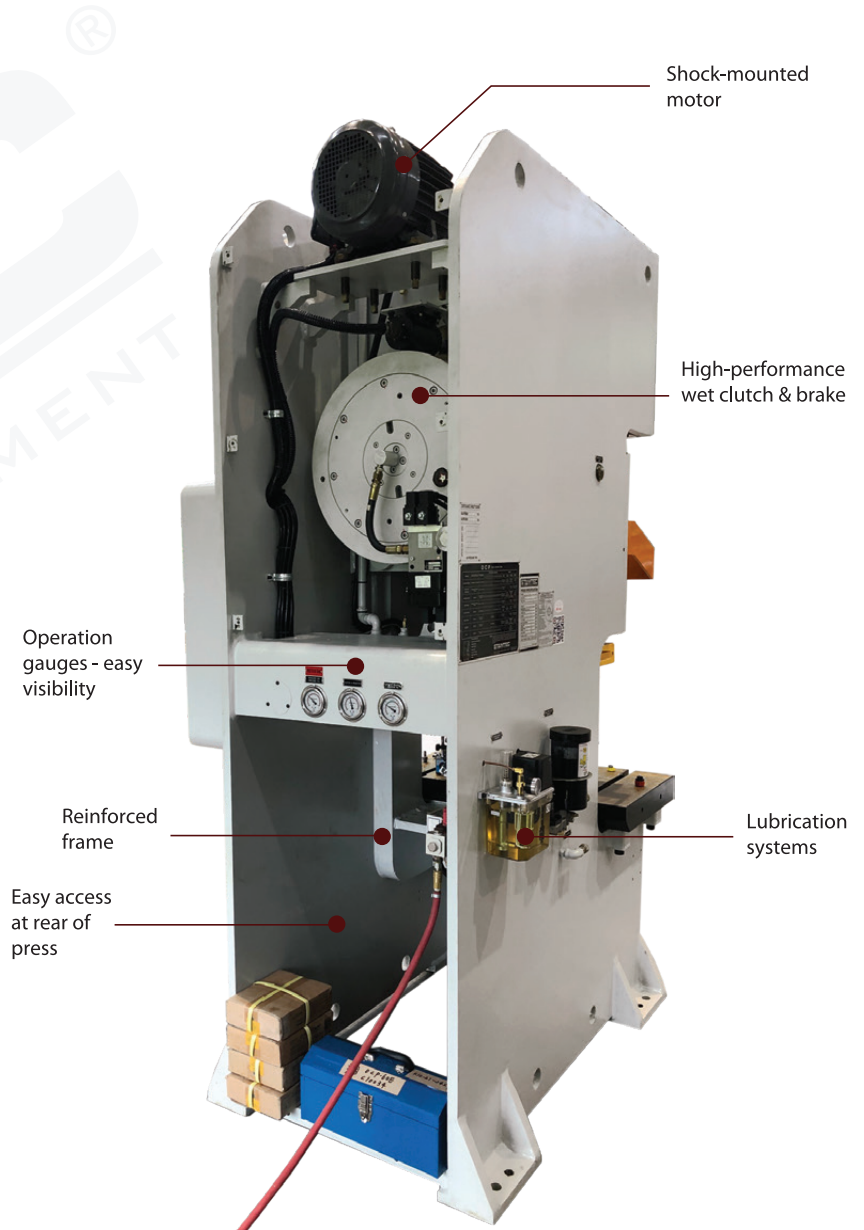

NOTE: Rear guard removed for photo.

Available On Request

- Bolster Drawing
- Slide Plate Drawing
- T-Slot Detail
- General Assembly Drawing

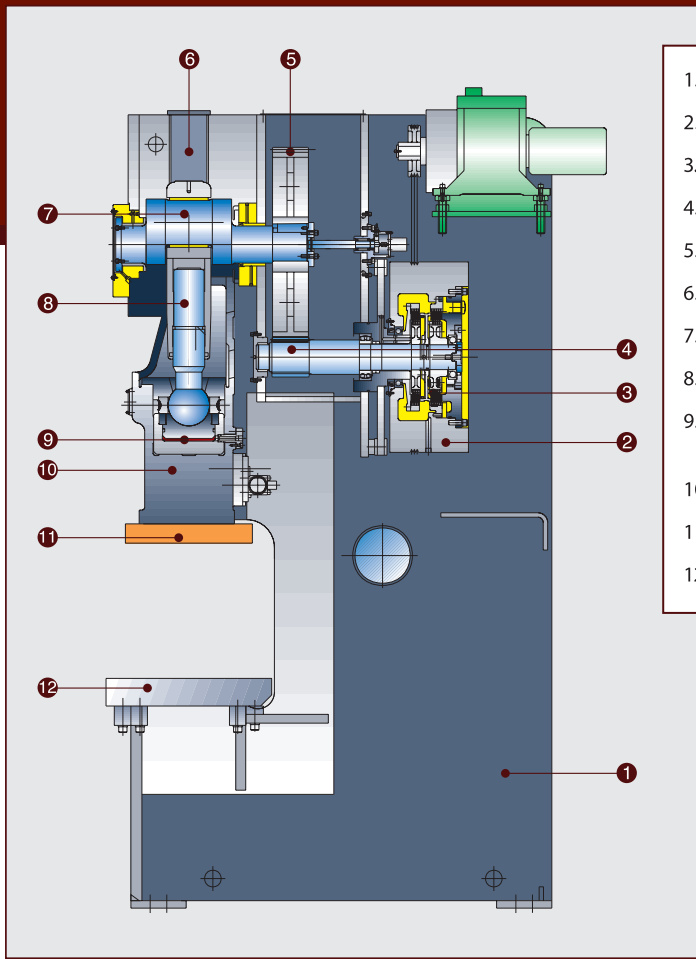

1. Press Frame
2. Flywheel
3. Wet Clutch & Brake
4. Pinion Drive Shaft
5. Main Gear
6. Counterbalance
7. Crankshaft
8. Adjusting Screw Frame
9. Hydraulic Overload Protector
10. Slide
11. Slide Plate (removable)
12. Bolster (removable)

Overload Protection

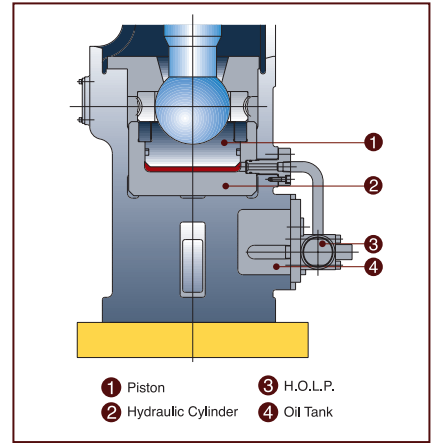

Fast response hydraulic overload relieves the pressure of a tonnage overload in milliseconds, stopping the press immediately. Hydraulic pressure is restored with the press of a button. Normal operation is inched to TDC. Your press and dies are effectively protected!

Six-Point, Extra-Long Precision Gibbing

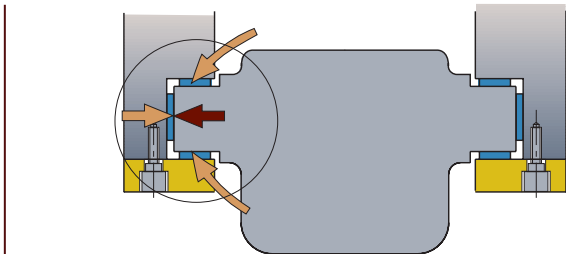

Extra-long gibs fully guide the slide during the working portion of the stroke. Force to the slide is delivered vertically, eliminating lateral thrust against the gibs, even under off-center loads.

Convenient Die Cushion Installation

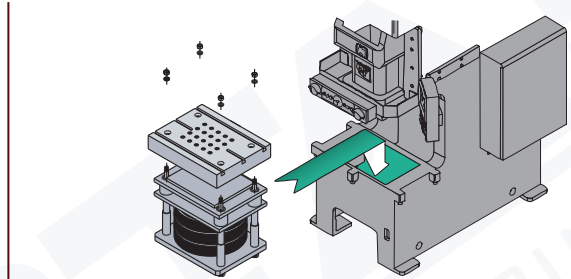

Optional die cushion is bolster-mounted for easy installation.

Super Rigid Steel Frame

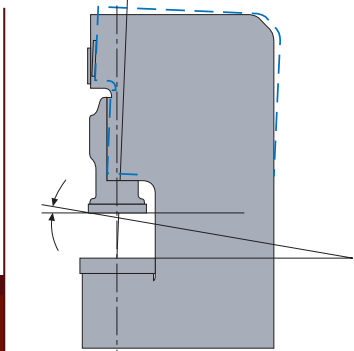

The heavy, one-piece welded steel frame is fully stress relieved and designed to resist deflection and provide accurate stampings and longer die life.

Minimize Frame Deflection

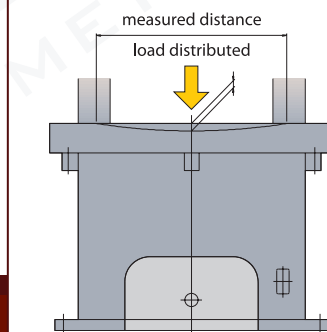

Exceptional resistance to deflection is a hallmark of Stamtec press design. You'll be impressed with the part quality and die life that the OCP delivers.

Auxiliary Equipment

Press Controls & Monitoring and Quick Die Change

Press Controls & Monitoring

Stamtec presses feature advanced, user-friendly press controls with fully programmable on-screen displays for easy set-up, start-up, operation & diagnostics.

Our standard presses come equipped with **OmniLink 5100-MPC Press Controls**.

Link's custom engineered OmniLink System 5100-MPC part revolution mechanical power press controls provide unmatched features and flexibility to achieve the ultimate in pressroom productivity and safety at modest cost.

OmniLink 805 Operator Terminal: The user friendly OmniLink 805 Operator Terminal uses a Color 5.7" LCD TFT with 640 x 480 pixel resolution and touch screen.

OmniLink System 5100-MPC Press Controls are designed to meet all functional safety requirements of current and anticipated OSHA 29 CFR 1910.217, ANSI B11.1, and CSA Z142 standards, and to provide safety features in addition to these standards when properly applied, adjusted, installed and used.

Stamtec presses can be CUSTOMIZED with your choice of press controls from:



Quick Die Change System (Q.D.C.)

Die Clamp TX-type
With "U" Cut in die set

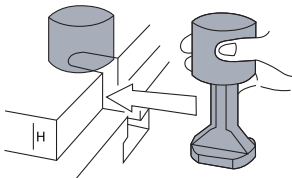

Die Clamp TY-type
Die plate thickness, H, to be specified

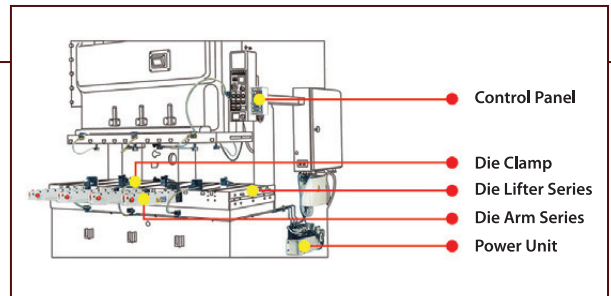
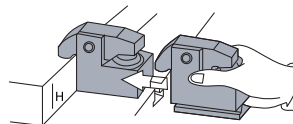

Stamtec carries a full line of quick die change components, including hydraulic power units, clamps, lifters, and bolster extensions. Quick die change systems can provide a number of important benefits, such as:

- Reduced downtime
- Greater productivity
- Longer tool life
- Better part quality
- Increased speed
- Improved employee safety





Stamtec has been providing dependable, affordably priced metal stamping presses for nearly 40 years in North America, and more than 70 years worldwide through our parent company Chin Fong. Our 72,000 sq. ft. sales, service, logistics, and assembly facility in Tennessee is home not only to North America's largest inventory of new presses and spare parts, but also our most important asset - our people. Our staff of engineering, sales, service, and support personnel are here to serve you in the most timely and professional manner. So, tap into our global strength, and grow with us as we grow with you!



Gap Frame Presses



Straight Side Presses



Servo Presses



Forging Presses



Coil Feeding & Handling Systems

STAMTEC®

METAL STAMPING & FORMING EQUIPMENT

STAMTEC, INC.

4160 Hillsboro Highway
 Manchester, TN 37355 U.S.A.
 TEL: +1-931-393-5050
 FAX: +1-931-393-5060
stamtecpresses@stamtec.com
www.stamtec.com

STAMTEC EQUIPOS de ESTAMPACIÓN

Cerrada la Noria No. 200 Int. B-10, Querétaro Park II,
 Parque Industrial Querétaro,
 Santa Rosa Jáuregui, Querétaro, CP. 76220
 TEL: +52-442-101-9555
stamtecpresses@stamtec.com
www.stamtec.com/es

